



## Expansion Vessels

N Range

DE Range

## Expansion Vessels

Our range of expansion vessels are now available in 3 formats.

10 bar DE Range with removable diaphragm suitable for heating, chilled water and potable water.

3 and 6 bar N Range with fixed diaphragm suitable for heating and chilled water.

Designed to absorb volumetric expansion or contraction in heating, domestic hot water and chiller systems.

The range is available with models up to 1000 litres capacity and are protected in a stove enamelled powder coating.

All models 35 litres and above are supplied with substantial support legs. The 25 litre unit and below are designed for wall mounting.



## N Range

Benefits:

- For heating and chilled water applications
- Max. operating temperature 120°C
- Meets or exceeds CE norms for pressure vessels 97/23/EC
- Factory pre-set pressure
- Durable powder coating finish
- Threaded connections

## DE Range

Benefits:

- For heating, chilled and potable water applications
- Max. operating temperature 95°C
- Meets or exceeds CE norms for pressure vessels 97/23/EC
- Replaceable diaphragm
- Factory pre-set pressure
- Durable powder coating finish
- Heavy gauge steel RST 37-2
- All vessel parts in contact with water are coated against corrosion
- Threaded connections

## N Range Technical Data

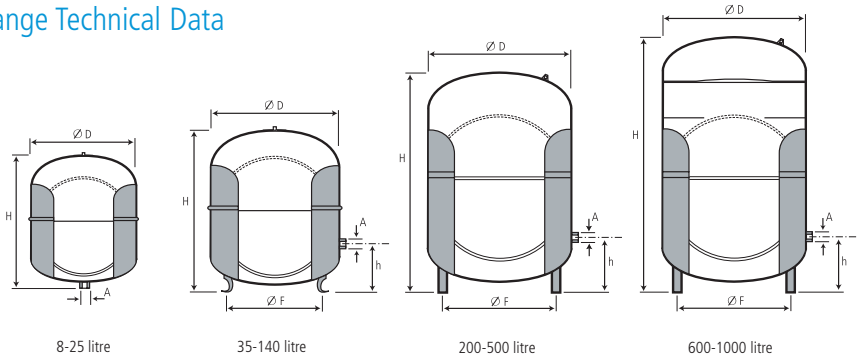

Model	Ø D	H	h	Ø F	A	Weight
<b>3 bar / 120°C</b>						
N 8/3	272	233			3/4"	1.9
N 12/3	272	315			3/4"	2.6
N 18/3	308	360			3/4"	3.5
N 25/3	308	480			3/4"	4.6
N 35/3	376	465	130	320	3/4"	5.4
<b>6 bar / 120°C</b>						
N 50/ 6	441	495	175	340	3/4"	12.5
N 80/ 6	512	570	175	370	1"	17.0
N 100/ 6	512	680	175	370	1"	20.5
N 140/ 6	512	890	175	370	1"	28.6
N 200/ 6	634	785	225	485	1"	36.7
N 250/ 6	634	915	225	485	1"	45.0
N 300/ 6	634	1085	225	485	1"	52.0
N 400/ 6	740	1075	225	570	1"	65.0
N 500/ 6	740	1295	225	570	1"	79.0
N 600/ 6	740	1530	245	570	1"	85.0
N 800/ 6	740	1990	245	570	1"	103.0
N 1000/ 6	740	2430	245	570	1"	120.0

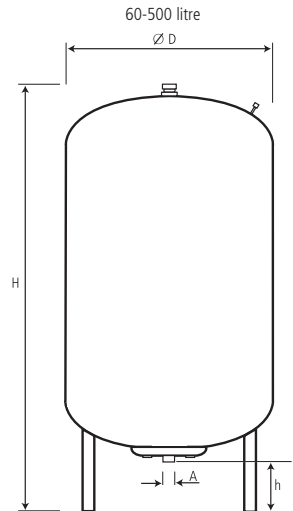

## DE Range Technical Data

Model	Ø D	H	h	A	Weight
<b>10 bar / 95°C</b>					
DE 60	409	740	160	1"	25.0
DE 80	480	730	152	1"	27.0
DE 100	480	840	152	1"	32.0
DE 200	634	980	144	1 1/4"	50.0
DE 300	634	1280	144	1 1/4"	55.0
DE 500	740	1485	133	1 1/4"	85.0

## Sizing the System Expansion Vessel

Graph 1

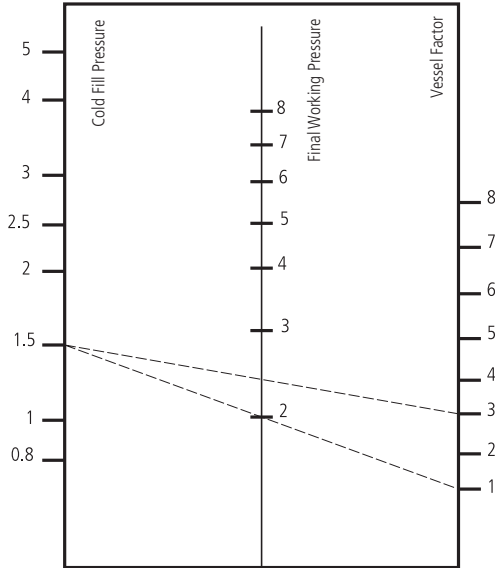

Table 1 - Calculation of System Factor

		Maximum System Temperature °C													
		30	35	40	45	50	55	60	65	70	75	82	85	90	
VESSEL FACTOR	8	0.01	0.014	0.018	0.023	0.028	0.033	0.038	0.044	0.052	0.058	0.067	0.072	0.08	
	7	0.012	0.016	0.02	0.026	0.031	0.037	0.042	0.05	0.057	0.064	0.073	0.082	0.09	
	6	0.014	0.018	0.023	0.029	0.036	0.042	0.05	0.057	0.066	0.074	0.083	0.091	0.103	
	5	0.015	0.02	0.027	0.034	0.041	0.05	0.057	0.066	0.077	0.085	0.10	0.108	0.117	
	4	0.019	0.025	0.032	0.04	0.05	0.06	0.068	0.079	0.092	0.105	0.12	0.13	0.143	
	3	0.023	0.03	0.04	0.05	0.062	0.074	0.085	0.10	0.114	0.13	0.15	0.16	0.18	
	2	0.03	0.04	0.054	0.069	0.082	0.10	0.115	0.133	0.155	0.17	0.20	0.22	0.24	
	1	0.045	0.06	0.08	0.1	0.125	0.15	0.175	0.20	0.23	0.26	0.30	0.325	0.3675	

### Step 1 – Select the parameters

The following factors affect the vessel selection and the appropriate values should be assigned:

1. Total height of system
2. Flow/return temperature
3. Pressure developed by circulating pump(s)
4. Maximum allowable pressure in system as dictated by components in system (i.e. radiator, boilers, heater batteries)
5. System water content

### Step 2 – Calculate the cold water fill pressure

The cold water fill pressure must be in excess of the static head exerted by the height of the water in the system, above the pressurisation unit.

i.e.  $\frac{\text{Height of system in metres} + 3}{10} \times 10 = \text{Cold fill pressure (bar)}$

\*allow extra 3 metres to assist venting

N.B. The cold fill pressure is also the air/nitrogen charge pressure in the expansion vessel

Example:

Height of system = 12m then

$\frac{12 + 3}{10} = 1.5$  bar cold fill pressure and vessel charge pressure

### Step 3 – Calculate the final working pressure

In strict theory the final working pressure would be calculated by assessment of maximum allowable system pressure, as dictated by the components in the system, and their vertical position in the system relative to the lowest point in the system.

In practice, a final working pressure of between 0.5 and 1.5 bar above the cold fill pressure is acceptable.

N.B. In heating systems the final working pressure will always be above the cold fill pressure. In chilled water systems it will always be below.

### Step 4 – Calculating the vessel factor

Example: Maximum allowable pressure in the system = 4 bar. Assume a cold fill pressure as calculated in step 2 = 1.5 bar and a final working pressure of 2.5 bar is selected, then the vessel factor of 3 is interpolated from Graph 1, or if a

final working pressure of 2.0 bar is selected, the vessel factor would be 1 (The higher the vessel factor, the smaller the vessel).

We would recommend that if any doubt arises you should contact our technical department, as in certain circumstances the maximum allowable pressure can be quite low, i.e. cast iron pipework systems.

### Step 5 – Obtaining the system factor

Using the vessel factor interpolated from Graph 1 and the maximum system temperature, select a system factor from Table 1.

Example: A vessel factor of 3 and maximum system temperature of 82°C will give a system factor 0.15.

Please note: for chilled water systems we recommend using 30°C as the maximum system temperature

### Step 6 – Calculating the expansion vessel size

Obtain vessel selection by multiplying system water content\* say in this instance 1200 litres x 0.15 = 180 litres

Recommended vessel = 200 litres\*\* with 1.5 bar charge

\* When the water content of a heating system is not known, then an approximation can be used as follows:

For boilers and systems with a high water content assume 12 litres of water per kW of boiler or chiller power (output) e.g. a heating systems containing large cast iron pipe work.

For boilers and systems with a medium water content assume 10 litres of water per kW of boiler or chiller power (output) e.g. older systems.

For boilers and systems with a low water content assume 8 litres per kW of boiler or chiller power (output) e.g. new and modern systems.

If in doubt contact the Mikrofill technical department.

\*\* From the vessel technical data (see over) select the nearest larger vessel size to your calculation.



Notes