



Maxi Pressurisation Units
(Maxi, Maxi Plus & HP)

Installation and Maintenance Instructions

Contents

1	Dimensions	3
1.1	Installation	4
1.1	Mains/boosted cold water inlet	4
1.2	Connection to the system	5
1.3	Overflow.....	5
2	Electrical connections	6
2.1	Electrical diagram	6
3	Alarm conditions	7
3.1	Low water level alarm	7
3.2	System failure	7
3.3	High or low pressure alarms	7
3.4	Pump failure	7
3.5	Frequent use reset	8
3.6	Hours run facility	8
3.7	Hours run reset	8
4	Fault diagnosis.....	8
5	Manual override	10
6	Audible alarm override	10
7	Adjusting settings	10
8	Menu functions	11
9	Maintenance	11

Dimensions

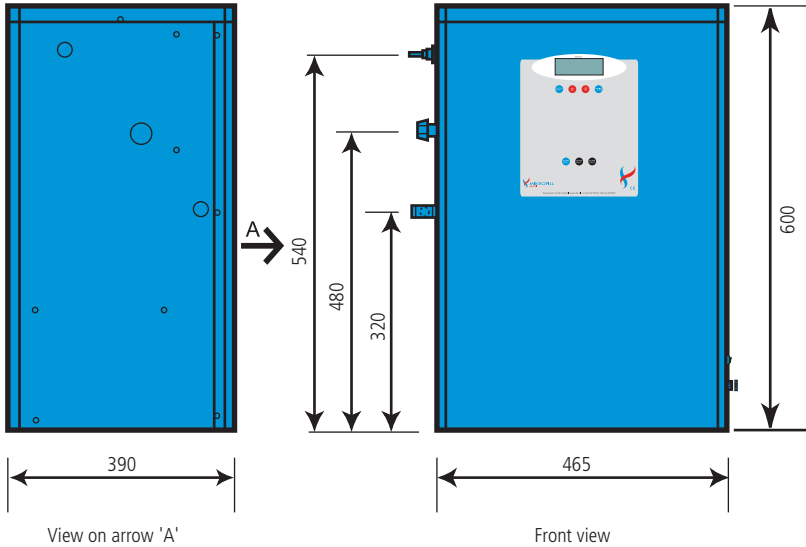

Typical installation diagram

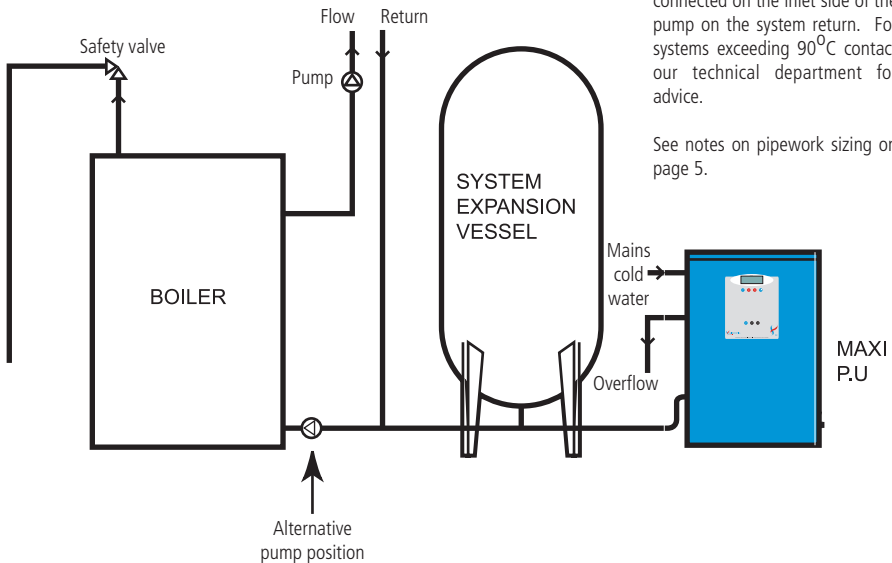

The expansion vessel is usually connected on the inlet side of the pump on the system return. For systems exceeding 90°C contact our technical department for advice.

See notes on pipework sizing on page 5.

Maxi & Maxi Plus pressurisation units

The Mikrofill Maxi range is a fully automatic heating / chiller system pressurisation device, and is suitable for the water management in all domestic and commercial heating and cooling systems. It is supplied as a fully commissioned unit and should require no "on site" commissioning.

.....

1 Installation

All Mikrofill products should be installed by a competent person with regard to the relevant requirements of the Health and Safety Regulations, Building Regulations, IEE Regulations, Water Supply (water fittings) Regulations, Water Bye-laws (Scotland) and any other local bye-laws or planning requirements.

The Mikrofill Maxi is intended for floor mounting: the unit should be situated in such a position as to enable the liquid crystal display to be easily read.

.....

1.1 Mains/boosted cold water supply

The Mikrofill Maxi is designed to be connected directly to the mains cold water supply, or a boosted cold water supply, the unit is supplied complete with all necessary isolating valves, but an inlet water isolating valve is recommended. The water inlet is 15mm compression and should be connected to the mains cold water supply by 15mm copper tube or equivalent approved plastic pipework. If the Mikrofill Maxi is sited some distance from the mains cold water supply it may be advisable to install a single check valve adjacent to the mains cold water supply.

To reduce the pressure drop on very long supply routes then 22mm supply pipework is recommended.



1.2 Connection to the system

The Mikrofill Maxi is connected to the heating/chiller system by way of the 15mm outlet valve, the pipework from the unit should be made in 15mm copper or similarly approved plastic pipework. A suitably sized expansion vessel should be incorporated into the system at this point. Please refer to typical installation diagram on page 3. If you require any assistance regarding vessel sizing please contact our technical sales department. The final connection into the heating/chiller system should be sized accordingly, recommendations are shown below:

- Vessel size up to 100L 1/2" (15mm) expansion pipework.
- Vessel size up to 300L 3/4" (22mm) expansion pipework
- Vessel size up to 1000L 1" (28mm) expansion pipework.

For vessel sizes in excess of 1000L capacity please contact our technical sales department.

IMPORTANT NOTE

The expansion vessel nitrogen/air charge must be set at the same pressure as the cold fill pressure of the system.* All Mikrofill expansion vessels are factory commissioned to the correct pressure.

* When the installed height of the expansion vessel is different to that of the MAXI then please contact our service department who will advise on the nitrogen/air charge.

.....

1.3 Overflow connection

The Maxi is supplied with a 3/4" bsp plastic overflow (warning pipe) connection which should be led to a drain and be visible at point of discharge, MIKROFILL SYSTEMS LTD cannot accept any responsibility for flood damage caused by failure to connect the overflow.

2 Electrical connections

The Mikrofill Maxi requires a permanent 230V 50Hz 1 phase supply rated at 6 amp. The unit is internally fused at 5 amp (see electrical installation diagram).

The Maxi also incorporates two BMS relays offering volt free contacts for the remote indication of high or low pressure conditions within the heating/chiller system. These relays are also independently fused at 5 amp to protect the Mikrofill Maxi from external electrical faults. A further volt free relay is included in the unit, this is to interlock the boiler or chiller control circuits. Should either of the alarm relays operate then the relay will shut down the boiler or chiller, indication of any alarm situation will be indicated on the display. The relays are suitable for use on control voltages up to 250V.

Once the Mikrofill Maxi has been correctly connected the unit is ready for use. Ensure that the unit has an adequate water supply and the service valves are open. Check for water leaks. Although every Maxi unit is factory tested it is still advisable to vent the pump(s) before operation. This is achieved by slackening the brass plug (14mm A/F), situated on the pump housing, until all air is eliminated. Switch on electrical supply to the unit and the illuminated on/off switch to the lower right hand side of the unit and the unit will start to pressurise the system. When the system has achieved the set pressure, the unit will stop filling, and go to standby.

Important note, "pump type" pressurisation units are not designed to fill systems from empty, they are only capable of "top up" and pressurisation. The system should be filled by other means in compliance with the water regulations. The Mikrofill Maxi is capable and approved to fill and pressurize heating/chiller systems.

2.1 Electrical diagram

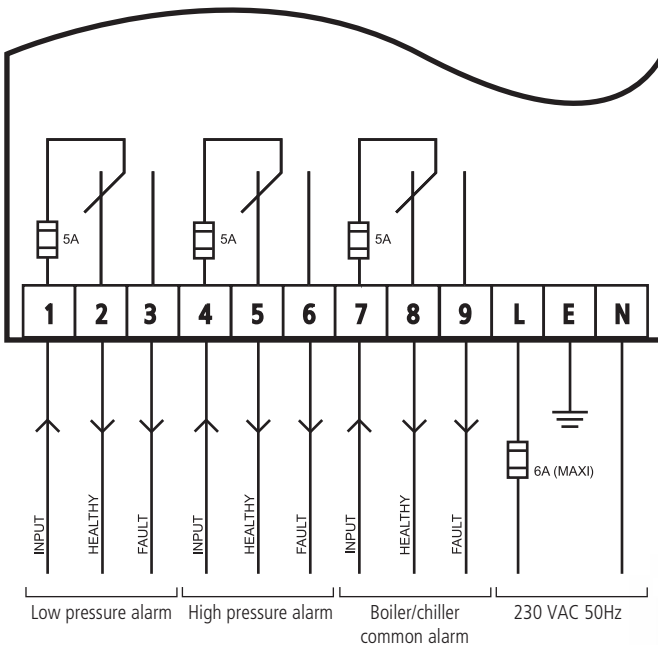

Electrical data

Supply: 230V 1ph 6 amp
 Full load current: 2.5 amp
 Start current: 4.5 amp
 Fuse rating: 6 amp
 BMS relays and boiler/chiller relays: volt free contacts rated at 250VAC at 5 amp
 All relays are independently fused at 5 amp

3 Alarm conditions

Please note the Maxi is a factory pre-commissioned product, should you require to change any of the preset parameters - please see "Settings".

.....

3.1 Low water level alarm

The Maxi continuously monitors the water level in the feed tank. If this falls to below an acceptable level then the unit will operate a safety shut down. When water level is reinstated the unit will automatically reset.

.....

3.2 System failure

The Maxi can differentiate between normal system fill rates and excessive water demand usually due to a flood condition. If this situation occurs the unit will shut down, and issue a flood alert warning on the LCD. This alert must be reset manually, by switching off the Maxi waiting 30 seconds and switching back on, if the leak has been rectified the unit will then operate as normal.

.....

3.3 High or low pressure alarms

If, for any reason the system water pressure reaches a high or low condition, as determined by the preset parameters the LCD will show the alarm message, the relevant BMS relay will operate and the Boiler/chiller control relay will shut down the boiler or chiller. When normal operating pressure is resumed the unit will automatically reset,

.....

3.4 Pump failure

The Maxi can also determine whether a pump has developed a fault. This is achieved by monitoring the system pressure and if an increase in pressure is not sensed in a set period of time it will stop operation of that pump and the "pump failure" message will appear on the LCD. If the Maxi Plus is used, it will automatically change to the remaining pump, and a pump failure message will be displayed.

3.5 Frequent use alarm

This alarm is to assist in diagnosing any leaks that may be present in the heating (or cooling system). If in any 24 hr period the Maxi operates more than a preset limit i.e. 5, then a frequent use alarm will show, (the operation of the system will not be affected, this function is for information only).

.....

3.6 Frequent use reset

This is achieved by switching the power supply to the unit off and on again.



.....

3.7 Hours run facility

This is accessed by scrolling the system data button.

.....

3.8 Hours run reset

This is achieved by depressing the   simultaneously.

IMPORTANT NOTE

The MAXI has a predetermined maximum fill rate of 12 litres per minute. Therefore, by multiplying the fill rate by the hours run the approximate water usage can be calculated.

.....

4 Fault diagnosis

System faults will be apparent from the alarm message displayed. The Maxi itself has a full self diagnostic microprocessor unit which continually self checks the operation, if an internal fault is diagnosed then the fault will be displayed on the screen, e.g. sensor disconnected.

Fault conditions

Fault indications	Cause	Remedies
Low water level	No water in tank	Reinstate water supply to tank
Sensor failure	Possible sensor fault	1. Switch unit off and back on, if sensor failure does not reappear on the display see note 2. If sensor failure does reappear check sensors are connected to the printed circuit board correctly. If the problem persists ring our service department.
	Incoming voltage instability	2. If this occurs switch the unit off and back on, the unit should then operate as normal. If this fault appears on a regular basis then a mains electrical filter (anti surge device) is required. Ring our service department for advice.
Low pressure alarm	System pressure low	Check system for leaks. Switch unit off and back on to reinstate. Check Low Alarm setting.
High pressure alarm	System pressure high	Reduce pressure in system and check expansion vessel air charge/size. Check High Alarm setting.
System failure	Possible excess water leak on the system	Check system for leaks, then switch unit off and back on to reinstate.
Pump failure	Possible pump fault	Switch unit off and back on to reinstate, if pump does not operate when required replace pump. If pump operates, dry run setting may need to be increased.
Frequent use alarm	Possible persistent leak on system	If the unit operates more than the set value in a 24hr period the unit will bring up the frequent use alarm, this will not stop the unit from operating but indicates that there may be a small leak on the system. Switch the unit off and back on to reinstate. Investigate possible leak.

The Mikrofill Maxi and Maxi Plus have been designed such that most apparent 'faults' can be remedied on site, if in doubt ring our service department on 01527 574574.

5 Manual override

Should the Mikrofill fail for any reason then a manual override facility can be employed. After ensuring that the heating system is charged with water, and that the Mikrofill is not indicating a system fault, rather than a unit fault i.e. flood alarm, then the BMS relays can be overridden by depressing the  and service buttons simultaneously for 3 seconds, repeating the operation will return the BMS relays to normal mode.

6 Audible alarm override



If the Mikrofill MAXI does indicate a fault, an audible alarm will sound, this can be overridden by depressing the service button.

7 Adjusting settings

The Mikrofill MAXI is supplied pre-commissioned with the settings as shown on the commissioning report. The setting can be adjusted on site as follows:

7.1 Press and hold the system data & service mode buttons simultaneously for approx 3 seconds

7.2 The display will indicate that you are now in the service mode

7.3 Use the 'system data' button to scroll through the settings, each setting can be adjusted by use of the   buttons. Section 8 describes the function of each setting

7.4 After adjusting the setting, the unit will return to its standard operating mode approximately 30 seconds after release of the buttons

7.6 Operating links



Link in MAXI operating mode



Link in MAXI PLUS operating mode



8 Menu functions

- Target low - this is the pressure at which the unit will operate i.e. start to fill. This is usually set at 0.2 - 0.3 below the target high
- Target high - this is the pressure at which the unit will cease filling i.e. the cold fill pressure
- Alarm low - the pressure at which the low pressure alarm relay will operate. Usually set 0.4 - 0.5 bar below the target low
- Alarm high - the pressure at which the high pressure alarm relay will operate. Usually set 0.5 bar below the system safety valve setting
- Hours run - for information only, no setting required. Please note, to zero the hours run the   buttons need to be pressed simultaneously for 3 seconds
- Dry run - this function affects the pump failure facility, the longer the dry run setting (which is calculated in minutes) the longer the unit will try to operate before notification of failure

Please note: where being used on a very large system the unit may indicate pump failure when it is operating normally, in this instance a longer dry run period may be required

- Delay off - this setting allows adjustment to prevent over or under shoot of the fill pressure - increasing time prevents under shoot, decreasing time prevents over shoot
- Frequent use - this setting warns of frequent use which would indicate a system leak and will show a warning message if in any 24 hour period the unit operates in excess of the frequent use setting
- Delay on - This setting is a further flood protection setting and reducing the setting will reduce the sensitivity of the flood protection
- Diff delay - no setting required

9 Maintenance

The inlet filter(s) which is housed in the service valve on the pump(s) inlet pipework should be checked and cleaned annually.

EXPANSION VESSELS - Charge pressure should be checked annually when the system is cold (the air charge pressure must equal the cold fill pressure of the Maxi).



Mikrofill Systems Ltd
West Court
Buntsford Park Rd
Bromsgrove
B60 3DX

T
+44 (0) 1527 574574

F
+44 (0) 1527 575565

W
mikrofill.com

E
info@mikrofill.com