

GN2 N ★★

**GAS/OIL FIRED
CAST IRON
FREE-STANDING BOILER**



FERROLI
COMMERCIAL



GENERAL DESCRIPTION

The GN2 N is a highly efficient boiler suitable for use with forced gas, pressure jet oil (28 or 35 sec) or dual fuel, with the option of ON/OFF or HIGH/LOW operating burners. GN2 N boilers are designed for use with fully pumped indirect heating systems to a maximum working pressure of 4 bar and flow temperature of 85°C against Δt 11°C. The pre-wired control panel incorporates ON/OFF illuminated switch, control and high/low thermostat, limit thermostat (manual re-set), thermometer and altitude gauge. For ease of maintenance all cleaning of the flueways is carried out from the front of the boiler, which means that the side clearances are kept to a minimum, making this boiler particularly suitable for modular installations. The electrical system and associated controls should be installed so that the burners are never allowed to fire when there is no demand for heat. Provision should also be made to dissipate residual heat on plant shutdown with the fitting of a pump overrun device. The GN2 N is CE approved and conforms to all the relevant European Standards.

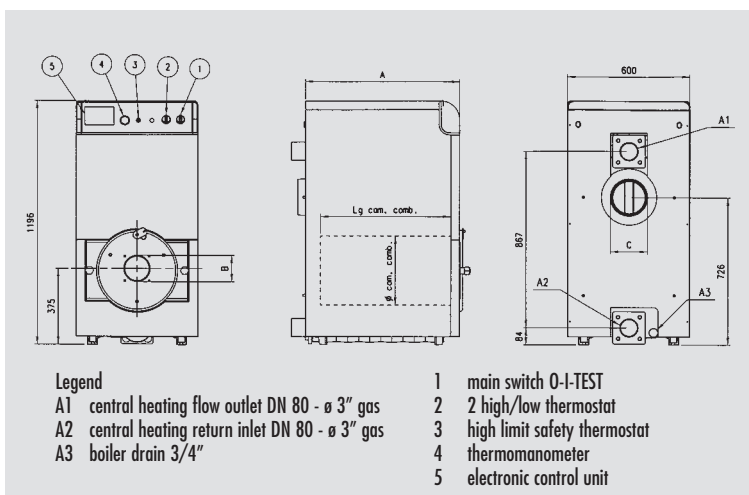

TECHNICAL DATA

MODELS GN2 N		05	06	07	08	09	10	11	12	13	14
DELIVERED HEAT OUTPUT	max. kW	90	108	126	144	162	180	198	216	234	252
	min. kW	73	87	101	115	129	143	157	171	185	199
HEAT INPUT (NETT)	max. kW	97.8	117.4	136.9	156.5	176	195.6	215.2	234.7	254.3	273.9
	min. kW	80	95	110	125	140	155	170	185	200	215
SECTIONS	n°	5	6	7	8	9	10	11	12	13	14
WATER CONTENT	dm³	49	57	65	73	81	89	97	105	113	121
COMBUSTION CHAMBER	length mm	505	615	725	835	945	1055	1165	1275	1385	1495
	diameter mm	400	400	400	400	400	400	400	400	400	400
WORKING PRESSURE	bar	4	4	4	4	4	4	4	4	4	4
A boiler length	mm	647	757	867	977	1087	1197	1307	1417	1527	1637
D flue diameter	ø	180	180	180	200	200	200	200	200	200	200
PRESSURE DROP COMBUSTION CHAMBER	Δp mbar	0.4	0.4	0.4	0.4	0.4	0.4	0.4	0.4	0.4	0.4
	WATER Δt 20° - Δp mbar	—	—	0.5	0.8	1.8	2.2	2.6	3.2	4	4.5
BOILER GROSS WEIGHT	kg	470	530	580	630	680	750	810	870	940	1000

MODULAR APPLICATIONS

This boiler range, is particularly suited for modular applications since all servicing and flue cleaning is carried out from the front, so that side clearances are kept to a minimum. For further details please contact FERROLI commercial boiler sales office.

BASE REQUIREMENTS

The boiler should stand on a load bearing non-combustible level base. Any plinth constructed must exceed the boiler plan area by not less than 80 mm overall.

INSTALLATION REQUIREMENTS

All GN2 N boilers should be installed in accordance with the relevant requirements of the building Regulations, Health and Safety Executive Regulation PMS, IEE Regulations and the Byelaws of the Local Authority and the local water company.

British Standard Codes of Practice

CP341.300-307: Central heating by low pressure hot water.

CP341.342: Part 2 Centralised hot water supply.

CIBSE Guide: Reference sections B7, B11 & B13.

IGE/UP/2: Gas Installation pipework, boosters and compressors on Industrial and Commercial premises.

BS6644: Installation of gas fired hot water boilers rated inputs above 60 kW but not greater than 2 Mw.

BS5410: Part 2 oil-fired installation of 44 kW and above.

VENTILATION

Safe, efficient, and trouble-free operation of conventionally flued gas boilers is vitally dependent on the provision of adequate supply of fresh air to the room in which the appliance is installed. Ventilation by grilles communicating directly with the outside, air is required at both high and low levels. The minimum free areas of these grilles must be in accordance with the table shown. The use of an extractor fan in the same room as the boiler (or in an adjacent room in communication) can, in certain conditions, adversely effect the safe operation of the boiler. Where such a fan is already fitted, or if an extractor fan is likely to be installed at later date, then further advice should be obtained.

Total gross input rating of boilers	Position of Air vents	Air vent areas (Air direct from outside)
Up to 2 MW	High Level	270 cm ² plus 2.25 cm ² per kW in excess of 60 kW total rated input
Up to 2 MW	Low Level	540 cm ² plus 4.5 cm ² per kW in excess of 60 kW total rated input

For further detailed recommendations consult BS5440 PART 2 and BS6644

ELECTRICAL DIAGRAM

- IL** ON/OFF switch
- CA** Auxiliary connection
- TR1** Control thermostat 1st stage
- TR2** Control thermostat 2nd stage
- TS** Limit thermostat manual re-set
- B1** Burner 1st stage
- B2** Burner 2nd stage
- 2ST** Contact 2nd stage

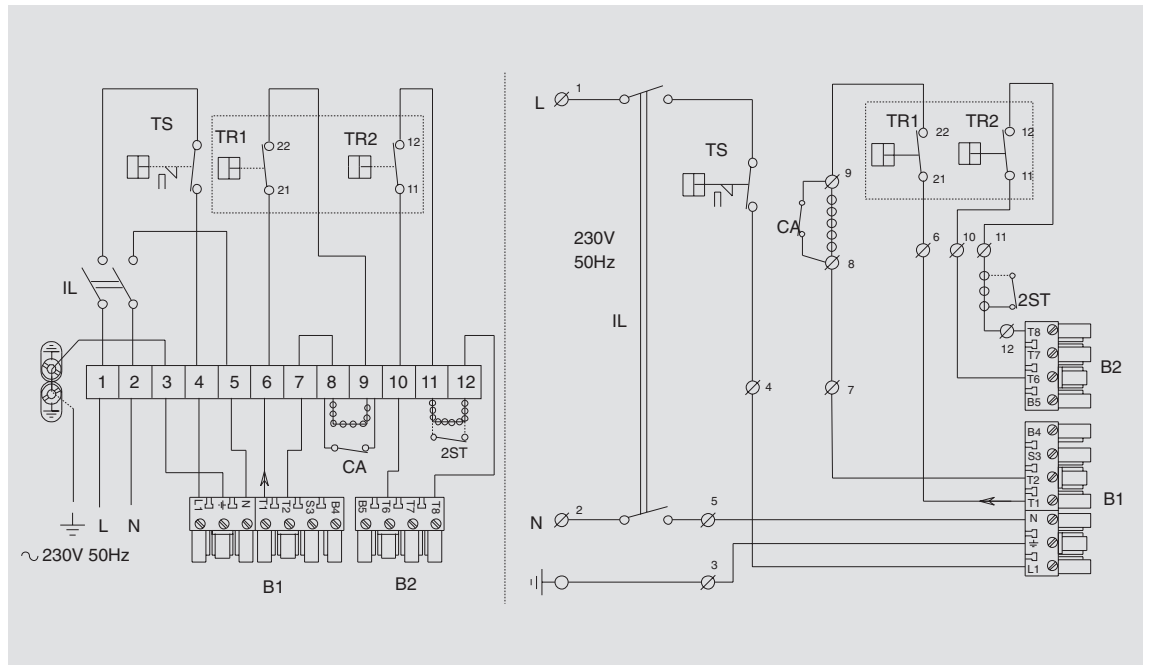

WATER TREATMENT

Water contained in all heating and indirect hot water systems, particularly open vented systems, requires basic treatment. It is wrong to assume that because boilers are operating in conjunction with what is an apparently closed circuit, an open vented system will not under normal circumstances allow damage or loss of efficiency due to hardness salts and corrosion once the initial charge of water has been heated several times. One millimetre of lime reduces the heat conversion from flame via metal to water by 10%. In practice the accumulation of these salts is liable to cause noises from the boiler body or even premature boiler failure. Corrosion and the formation of black iron oxide sludge will ultimately result in premature radiator failure. Open vented systems are not completely sealed off from the atmosphere because it is necessary to provide a tank open to atmosphere if proper venting and expansion of system water is to be achieved. The same tank is used to fill the systems with water and it is through the cold feed pipe that system water expands into the tank when the boiler passes heat into the system. Conversely, when the system cools, water previously expanded is drawn back from the tank into the system together with a quantity of dissolved oxygen. Even if leakage from the heating and hot water system is eliminated there will be evaporation losses from the surface of the tank. Depending on ambient temperature these may be high enough to evaporate a large portion of the system water capacity over a full heating season. Corrosion will always occur within a heating/hot water system to a greater or lesser degree irrespective of water characteristics, unless the initial fill water from the mains is treated. Even the water in closed systems will promote corrosion unless treated.

PRODUCT RANGE

BOILERS

WALL-MOUNTED BOILERS

With or without water production, these high performance, electronic and fully modulating systems are suitable for both hot water and heating applications. Models with outputs from 6 kW to 35 kW.

CAST IRON BOILERS ATMOSPHERIC GAS FIRED

High performance, with or without hot water production; models with outputs from 10 kW to 289 kW.

CAST IRON BOILERS PRESSURE JET OIL AND GAS FIRED

High performance, with or without hot water production, some models operate at low temperature. Models with outputs ranging from 17 kW to 650 kW.

HOT WATER STORAGE CALORIFIERS

From 100 to 500 litre capacity.

WELDED STEEL BOILERS

High performance models with outputs ranging between 87 kW and 10,465 kW for hot water, superheated hot water and steam up to 15 bar.

SOLID FUEL BOILERS

These units are ideal for burning wood chips and fluid fuels (2 fuels) with output ranging between 174 kW and 6,990 kW for production of hot water superheated hot water and steam up to 15 bar.

AIR-CONDITIONING

A complete range of products for air-conditioning ranging from mobile units, single and multisplit units, with chillers up to 143 kW.

WHIRLPOOL BATH

An exclusive range of whirlpool and showers complete with accessories are available in 4 colours.

ALL FERROLI BOILERS ARE CE APPROVED AND CONFORM TO THE RELEVANT EUROPEAN STANDARDS.

*Ferrolì pursues a policy of continuous product improvement and reserves the right to alter specifications, design and price without prior notice.
All information was correct a time of going to print.*

